

The background of the advertisement features a collage of various kitchen accessories. In the upper left, there is a metal mesh strainer. Below it is a dark-colored frying pan with a handle. To the right, a portion of a dark-colored tray with circular indentations is visible. In the lower right, a stainless steel sink with a perforated drain is shown. The bottom left corner features a dark-colored plastic or metal grid. The overall composition is a close-up, angled view of these items, emphasizing their industrial and durable nature.

RATIONAL accessories.

Robust. Durable.
Tough.



Hot and fully loaded.

The accessories for the iCombi can withstand a lot.

It has to be robust enough to last every day and be able to work hard in the professional kitchen – only then will the grill and pizza tray, mobile oven rack, CombiFry and condensation hood earn the right to bear the name original RATIONAL accessories. Only then can you make full use of the outstanding performance of the iCombi Pro and of the iCombi Classic. Everything from pre-fried products, chicken, baked goods and grilled vegetables will be a complete success. Also the steak will have distinctive grill stripes. So you get the most out of your cooking system. You no longer need to stay behind and deal with stubborn dirt, unnecessary damage and overheated accessories.

➔ **Durable accessories**

So that everything turns out as you imagined. Each and every time.



2



3



4



1



5



6

7



8



9

Grilling and frying.

Higher productivity, better results.

TriLax coating

The RATIONAL accessories coated with TriLax have excellent heat conductivity, they have been developed for grilling, frying, roasting and baking and can be used in temperatures up to 300 °C. The robust non-stick coating also supports browning.

1 Roasting and baking tray

The universal tray for fish, meat, poultry pieces, roast potatoes, baked goods, vegetables and much more. Juicy with a nice crust.

2 Grilling and roasting tray

For juicy grilled meat, fish or vegetables. With a grill side for a traditional grill pattern and a frying side with a rim around the edge for pan fried food. The ideal addition for your à la carte service.

3 Grill and pizza tray

Two different sides with just one tray. Baking side for fresh or convenience pizza, quiches and flatbreads. Grilling side for vegetables, fish and meat.

4 Multibaker

Optimal portioning and consistent product sizes for fried eggs, omelettes, hash browns and tortillas.

5 Cross and stripe grill grate

With the classic grill stripes on the one side or the original American steakhouse pattern on the other. Extremely robust and durable. No preheating necessary.

6 CombiGrill griddle

For the preparation of large batches of grilled products. Preheating the grid is not necessary.

7 Loading grid

Ideal addition to the CombiGrill griddle. For thin grilled products such as minute steaks or grilled vegetables. Place the food to be cooked on the loading grid, place it on the hot CombiGrill griddle and later remove.

8 Roasting and baking pan

For classic pan dishes such as hash browns, tortillas, quiches, pancakes or small cakes such as tarte tatin. Griddled surface for fast heat input. With carrier tray for easy handling.

9 Granite-enamelled container

With fully contoured corners so no portion of any bake is lost. Thanks to the excellent heat conductivity, it is ideal for roasting, braising, pan-frying and baking. Almost indestructible.

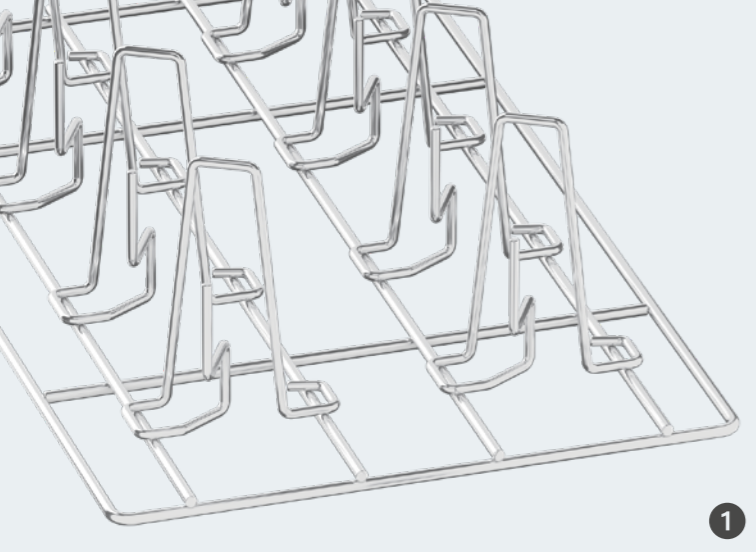

1

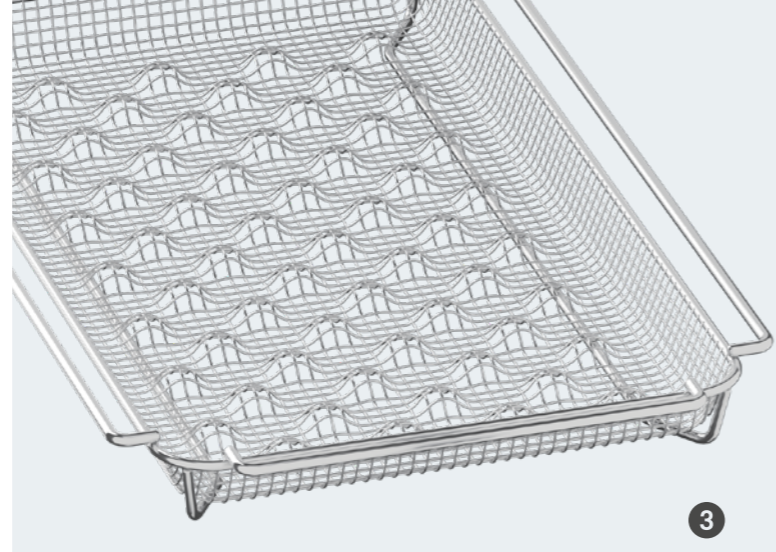

3

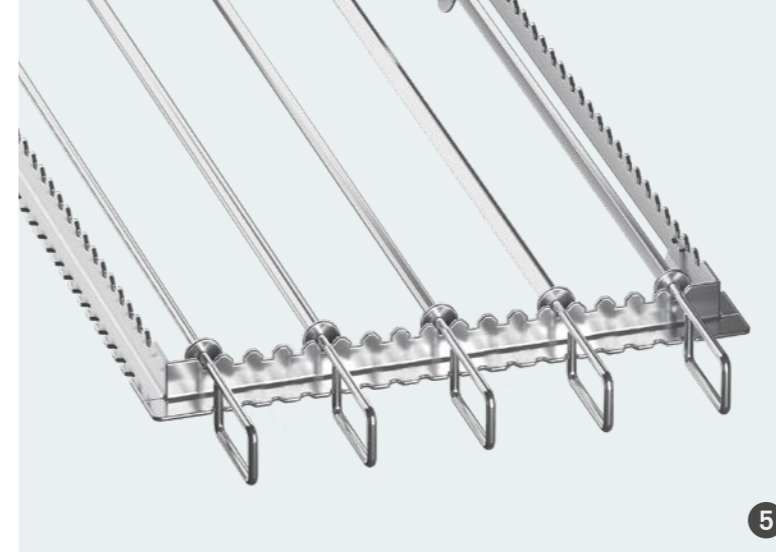

5

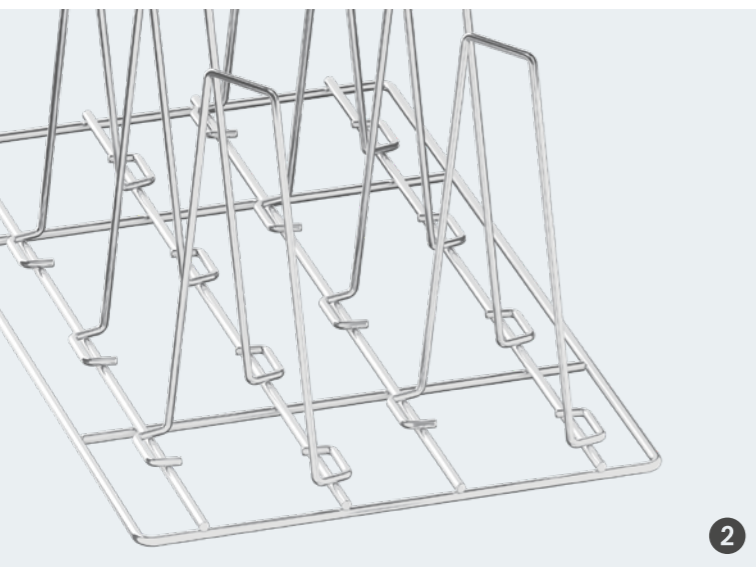

2

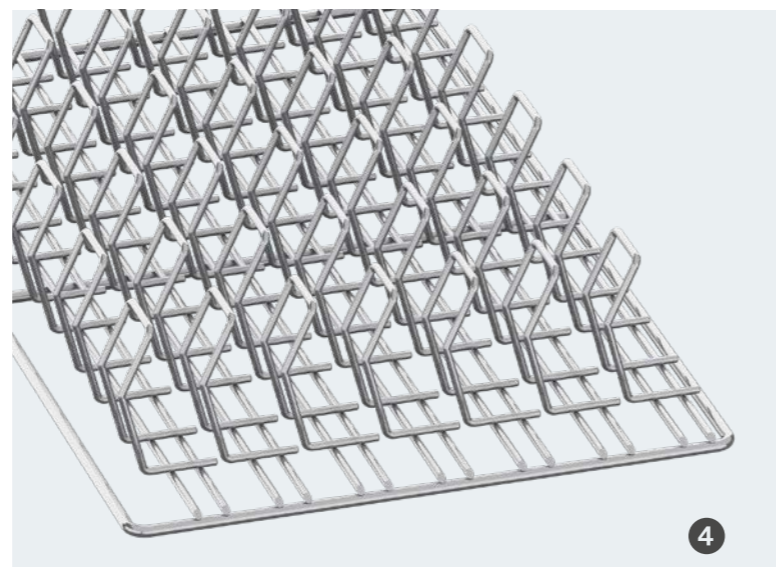

4

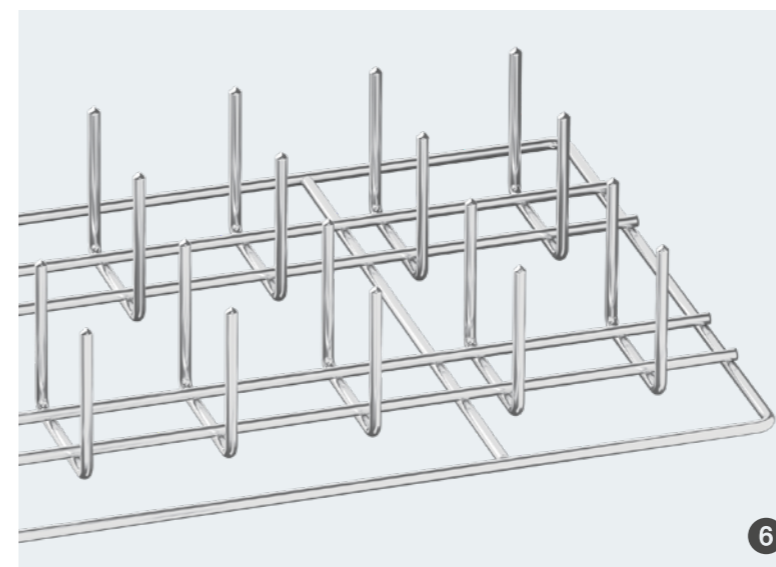

6

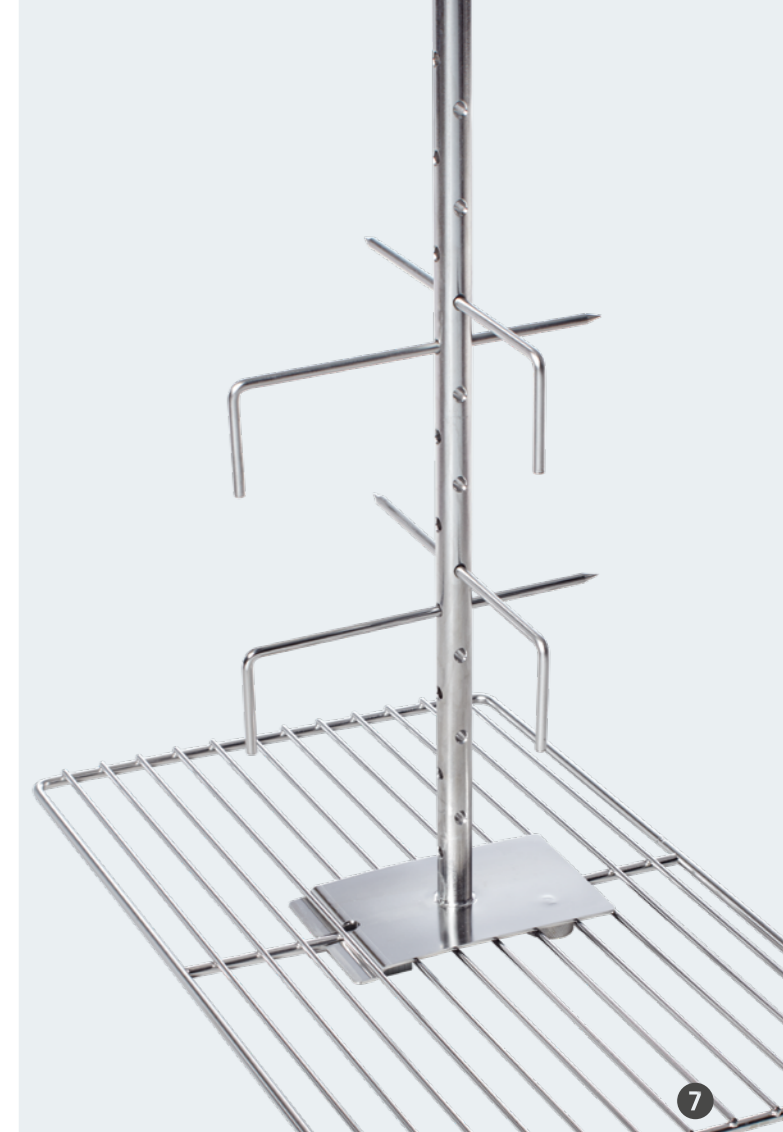

7

Special applications.

Special accessories for special requirements.

1 2 Chicken and duck superspike

Significantly reduced cooking time thanks to upright placement of poultry and the associated chimney effect. For succulent breast meat and uniformly browned skin.

3 CombiFry

Large quantities of pre-fried products such as fish nuggets, chips and wedges with no added fat. Healthy and delicious.

4 Ribs rack

Optimal utilisation of the unit thanks to the vertical arrangement of the spare ribs with up to 3.5 kg per grill.

5 Grill and tandoori skewer

With round, square or rectangular cross-sections in different diameters for meat, fish, poultry or vegetables.

6 Potato baker

Cook baked potatoes or corn on the cob without aluminium foil and up to 50 %* faster.

* Compared to conventional kitchen technology.

7 Lamb and suckling pig spit

Easily prepare entire lambs or suckling pigs of up to 30 kg.



1



2



3



4

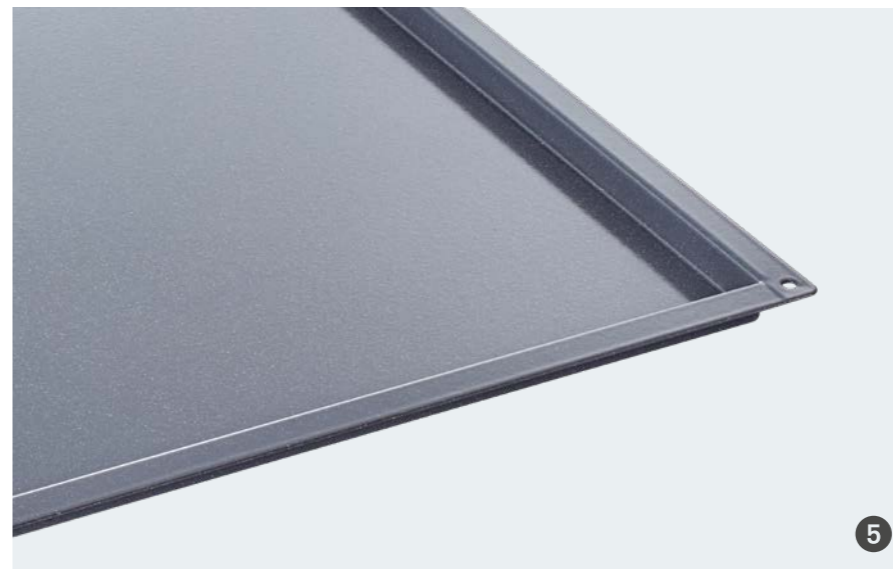

5



6



7

Baking.

This is quality craftsmanship.

1 Muffin and timbale mould

Made from highly flexible material and has optimal non-stick properties for muffins and desserts. 100 ml filling volume.

2 Roasting and baking pan

Perfect for for small cakes like tarts tatin. The griddled base ensures fast heat input over the entire base. With special contoured carrier tray for easy handling.

3 Roasting and baking tray

The universal genius for baking: Bread rolls, croissants, danish pastries and much more with uniform browning, crispy crusts and fluffy interior.

4 Perforated baking tray

Ideal for bread, bread rolls, pretzels and for the production of all types of pre-baked products.

5 Granite-enamelled container

The corners of the containers are fully contoured so that no portions of cakes are lost. Excellent heat conductivity for uniform browning and light and airy tray bakes.

6 Mobile oven rack in bakery standard

A mobile oven rack replaces one hinging rack. For quick loading and unloading, made from high-grade stainless steel for high quality requirements and perfectly tailored to RATIONAL units.

7 Bakery standard hinging rack

Thanks to the L-shaped racks, the hinging racks can easily be loaded with baking trays. The larger rail distance means the total capacity of the RATIONAL unit can also be used for higher baked goods. Made from high-grade stainless steel for top quality requirements.



1



2



3



1



2



3

GN accessories.

Better by default.

1 Perforated container

Versatile, robust and durable accessory for steaming vegetables or for your buffet. Maximum perforation means the food is evenly steamed, and retains its colours and nutrients.

2 Containers

The material thickness of stainless steel RATIONAL containers is 33 % above the standard. This guarantees maximum stability even for large quantities, long service life and convenient handling without any sharp edges.

3 Grid

Ideal for cooking large roasts. Made from extremely stable and durable stainless steel.

Extras.

Even more possibilities.

1 VarioSmoker

Achieve smoky flavours directly from the combi-steamer. The VarioSmoker gives meat, fish and vegetables a natural smoky flavour; you can refine the intensity according to your preferences. Even low-temperature cooking is not a problem. Getting started with smoking is simple, thanks to plug & play: The intelligent cooking paths of the iCombi Pro regulate the VarioSmoker via the USB connection, guaranteeing an optimal and professional cooking and smoking result.

2 Pull-out rails

Smooth pull-out for cooking accessories facilitates quick loading and unloading of products in à la carte operation.

3 Externally attachable core probes

A special extra thin sous-vide core probe ensures that the core temperature of the product is achieved precisely without destroying the vacuum in the bag. The externally mounted core temperature probe can be used as a replacement option for the internal core temperature probe.



Finishing.

Consistent separation of production and output.

❶ System for banqueting

20, 100 or several thousands of meals – with Finishing food is perfectly prepared without the stress, hectic rush or labour cost. Simply plate the appropriate number of plates cold and store them chilled in the mobile plate rack. The plates are then finished simultaneously using the Finishing process shortly before service. The Finishing system includes all accessories needed to start immediately (mobile plate rack, Thermocover, transport trolley).

❷ Mobile plate racks

Made from high-grade stainless steel and perfectly tailored to the units. For fast loading and unloading for up to 120 plated plates in the iCombi Pro 20-2/1 (up to 31 cm diameter).

❸ Thermocover

From special insulating materials to keep food hot for up to 20 minutes after Finishing. Easy to open and close with the simple magnetic seal. It is also easy to clean and store.

❹ Run-in rail

For quick, ergonomic loading and unloading of mobile oven racks or mobile plate racks. Required for tabletop units Model 6-1/1, 6-2/1, 10-1/1 and 10-2/1.

❺ Transport trolley

Simple loading and unloading of the mobile oven rack in tabletop units. Safely transport food thanks to the large, quiet and hygienic tandem castors. Tailored to the height of the stand. Height-adjustable version for worktops.

❻ Transport trolley for Combi-Duo

Safely load and unload both units in a single operation. A separate run-in rail for Combi-Duo is required.



Combi-Duo.

Double the power.

1 Combi-Duo

Two units, easily combined. When there is little available space but you still need to steam and grill at the same time and the workload is the same, Combi-Duo provides two units which you can choose to control from the top unit. For more convenience. For more flexibility.

2 Integrated fat drain kit for Combi-Duo

Reliably collects dripping fat in the cooking cabinets and drains it into drip trays. Different versions available depending on the setup variation.



3 Setup variations for Combi-Duo

The levelling kit and the stands are made from high-grade stainless steel for stable and correct setup.

The setup variations:

- › With a levelling kit to compensate for uneven floors: Low variation with low rack height, requires a floor drain.
- › Mobile kit with castors for easy cleaning and low rack height, requires a floor drain.
- › Fixed setup with stand II for Combi-Duo or substructure with feet. No floor drain necessary.
- › Mobile setup with stand II for Combi-Duo with swivel castors and parking brakes.



Stands.

Stable. Space-saving. Practical.

4 Levelling kit and stands

For the stable and balanced setup of your RATIONAL unit, we provide stands made from high-grade stable stainless steel in various versions: open, closed on the side or fully closed stands with doors. Support rails help store cooking accessories to save space. Mobile variations with stable castors and parking brakes enable the flexible positioning of the unit in the kitchen. All stands are designed in accordance with the applicable hygiene regulations.



Setup variations.

Convenient and practical.

❶ Installation kit for iCombi Pro XS

The appearance also counts – so you can also integrate the small cooking system with an installation kit in your front of shop area. Space for a hood is already provided so you can install an UltraVent or UltraVent Plus as needed. This is supplied with a trim kit included to prevent the accumulation of dirt in less accessible areas.

❷ MobilityLine floor cooking system (Model 20-1/1, 20-2/1)

A special frame with four robust castors and parking brakes, on which the floor unit is mounted, allows effortless mobility.

❸ MobilityLine tabletop unit (Model 6-1/1 – 10-2/1)

The tabletop unit is firmly screwed to Stand II MobilityLine. Side bars protect the unit and together with the large stable castors, they facilitate mobility.

Exhaust air technology.

For a good work climate.

All extraction and condensation hoods

- › Have a timeless modern design
- › Have an easy to clean front with a removable cover
- › Adjust the extraction capacity with intelligent infinitely variable control of the fan depending on the situation, such as when opening the door. Installation is simple, and the system can be retrofitted at a later time, too.

❶ UltraVent

With its condensation technology, the UltraVent absorbs steam and vapours. No connection to the outside or extension of an existing exhaust system is necessary with this air recirculation hood.

❷ UltraVent Plus

In addition to the UltraVent's condensation technology, the UltraVent Plus is equipped with special filter technology. This not only condenses vapours, but also reduces unpleasant fumes, for example when grilling and frying. RATIONAL units can be installed even in critical locations such as at the front of the store.

❸ Extraction hood

Steam and vapours are automatically extracted from the cooking cabinet and when opening the cooking cabinet door (without condensation technology). An external connection is required.

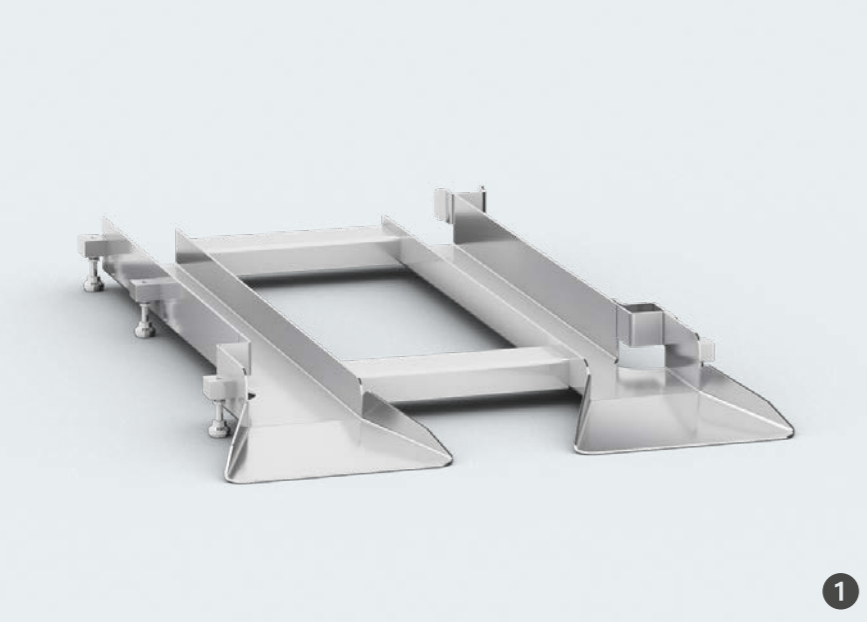

1



3



5



8



2



4



6



7



9

Installation accessories.

An answer to every challenge.

1 Trolley levelling device

The trolley levelling device compensates for inclinations (up to 3 %) in the kitchen floor ensuring that the mobile oven rack can be rolled smoothly into the RATIONAL unit.

2 Unit and mobile oven rack raiser

The ground clearance is increased by 70 mm. The mobile oven rack must be adjusted to the unit height accordingly.

3 Heat shield for right and left side panel

Retrofitting a heat shield allows you to place a radiant heat source (e.g. grill) near the right or left side panel.

4 Flow guard (for gas units only)

Used to extract exhaust gases through a pipe (diameter of exhaust gas pipe 180 mm).

5 Handle holder for mobile oven rack

Provides a fixed storage location for the mobile oven rack handle, so that it is always within easy reach (included with delivery of floor units).

6 Condensation breaker

Accelerates the expulsion of steam and other vapours from the vent pipe. Steam and vapours can thus be diverted through a pipe into an extraction system.

7 Table extension

Prevents the accumulation of dirt and water by sealing the protruding underside of the iCombi Pro 6-1/1 and 10-1/1 when installed on a 700 mm deep worktop.

8 Unit connection kit

Consisting of a water inflow hose (2 m) and waste water pipes DN 50.

9 Wall mounting

For space-saving wall mounting. The attachment and mounting material (not included) must be designed in consultation with an architect/structural engineer and the building owner.



1



3



5



7



2



4



6



8

Care products.

Hygienically clean.

1 Active Green cleaner tab (for iCombi Pro and iCombi Classic)

Keeps both the unit and the environment clean: The cleaner tab with its new formula is phosphate and phosphorous-free and reduces the quantity of cleaner by up to 50 %*. Without compromising on cleaning power and hygiene. Can perform an ultra-fast interim clean of the iCombi Pro in approx. 12 minutes.

2 Cleaner tab (for all SelfCookingCenter and CombiMaster Plus units)

Highly-concentrated and economical cleaner tabs with an intensive combination of active ingredients for high-performance cleaning power.

3 Care tab (for iCombi Pro, iCombi Classic and SelfCookingCenter units with Efficient CareControl)

Care substances actively protect against limescale in the steam generator and in the cooking cabinet before it even forms and extend the lifetime of the unit. Operational reliability without a water softener and time-consuming descaling.

4 Rinse aid tab (for SelfCookingCenter units without Efficient CareControl and CombiMaster Plus)

Active protection and extended lifetime thanks to high-efficiency care substances. Your cooking cabinet will be left gleaming with hygienic cleanliness.

5 Grill cleaner (for all CombiMaster and ClimaPlus Combi units)

Liquid cleaner for hygienic cleanliness and care.

6 Rinsing chemical, liquid (for ClimaPlus Combi with CleanJet)

7 Descaler (for SelfCookingCenter without Efficient CareControl, CombiMaster, ClimaPlus Combi)

For effective descaling of the steam generator with special care products.

8 Handheld pressure sprayer

Made of sturdy plastic, robust and easy to handle. The built-in pump mechanism generates the overpressure so that you can spray the areas to be cleaned at the push of a button with liquid cleaner or rinsing chemical.

* Compared to the previous Model.

Grilling, roasting and baking.



Perforated baking tray

2/3 GN (325 × 354 mm)	No.	60.74.147
1/1 GN (325 × 530 mm)	No.	6015.1103
2/1 GN (650 × 530 mm)	No.	6015.2103
Bakery standard (400 × 600 mm)	No.	6015.1000

Roasting and baking trays (unperforated)

2/3 GN (325 × 354 mm)	No.	60.73.671
1/1 GN (325 × 530 mm)	No.	6013.1103
2/1 GN (650 × 530 mm)	No.	6013.2103
Bakery standard (400 × 600 mm)	No.	6013.1003

Grilling and roasting tray

1/1 GN (325 × 530 mm)	No.	60.71.617
-----------------------	-----	-----------

Grill and pizza tray

2/3 GN (325 × 354 mm)	No.	60.73.798
1/1 GN (325 × 530 mm)	No.	60.70.943
Bakery standard (400 × 600 mm)	No.	60.71.237

Multibaker

1/3 GN (325 × 265 mm) 2 moulds	No.	60.73.764
2/3 GN (325 × 354 mm) 5 moulds	No.	60.73.646
1/1 GN (325 × 530 mm) 8 moulds	No.	60.71.157

Cross and stripe grill grate

1/2 GN (325 × 265 mm)	No.	60.73.802
2/3 GN (325 × 354 mm)	No.	60.73.801
1/1 GN (325 × 530 mm)	No.	60.73.314

CombiGrill griddle

1/1 GN (325 × 530 mm)	No.	6035.1017
-----------------------	-----	-----------

Loading grid

for CombiGrill griddle 325 × 618 mm (for 1/1 GN)	No.	60.73.848
--	-----	-----------

Roasting and baking pan

Small set (4 pcs including carrier tray)	No.	60.73.286
Large set (2 pcs including carrier tray)	No.	60.73.287
Roasting and baking pan, small (ø 16 cm)	No.	60.73.271
Roasting and baking pan, large (ø 25 cm)	No.	60.73.272
Carrier tray for roasting and baking pan, small	No.	60.73.212
Carrier tray for roasting and baking pan large	No.	60.73.216

Muffin and timbale moulds

300 × 400 mm (for 1/1 GN (325 × 530 mm))	No.	6017.1002
400 × 600 mm (for 2/1 GN (650 × 530 mm) and bakery standard)	No.	6017.1001

Granite-enamelled container

1/2 GN (325 × 265 mm) 20 mm deep	No.	6014.1202
1/2 GN (325 × 265 mm) 40 mm deep	No.	6014.1204
1/2 GN (325 × 265 mm) 60 mm deep	No.	6014.1206
2/3 GN (325 × 354 mm) 20 mm deep	No.	6014.2302
2/3 GN (325 × 354 mm) 40 mm deep	No.	6014.2304
2/3 GN (325 × 354 mm) 60 mm deep	No.	6014.2306
2/3 GN (325 × 354 mm) 100 mm deep	No.	6014.2310
1/1 GN (325 × 530 mm) 20 mm deep	No.	6014.1102
1/1 GN (325 × 530 mm) 40 mm deep	No.	6014.1104
1/1 GN (325 × 530 mm) 60 mm deep	No.	6014.1106
1/1 GN (325 × 530 mm) 100 mm deep	No.	6014.1110
2/1 GN (650 × 530 mm) 20 mm deep	No.	6014.2102
2/1 GN (650 × 530 mm) 40 mm deep	No.	6014.2104
2/1 GN (650 × 530 mm) 60 mm deep	No.	6014.2106
Bakery standard (400 × 600 mm) 20 mm deep	No.	6014.1002
Bakery standard (400 × 600 mm) 40 mm deep	No.	6014.1004
Bakery standard (400 × 600 mm) 60 mm deep	No.	6014.1006

Finishing.

Thermocover

Model 6-1/1	No.	6004.1007
Model 10-1/1	No.	6004.1009
Model 6-2/1	No.	6004.1016
Model 10-2/1	No.	6004.1014
Model 20-1/1	No.	6004.1011
Model 20-2/1	No.	6004.1012

System for banqueting

Model 6-1/1, 20 plates	No.	60.61.741
Model 10-1/1, 32 plates	No.	60.11.628
Model 10-1/1, 26 plates	No.	60.11.629
Model 6-2/1, 34 plates	No.	60.62.196
Model 10-2/1, 42 plates	No.	60.12.154
Model 10-2/1, 52 plates	No.	60.12.155
Model 20-1/1, 60 plates	No.	60.21.332
Model 20-1/1, 50 plates	No.	60.21.333
Model 20-2/1, 120 plates	No.	60.22.493
Model 20-2/1, 100 plates	No.	60.22.492
Model 20-2/1, 84 plates	No.	60.22.491

Finishing.



Mobile plate rack

Model 6-1/1, 20 plates	No.	60.61.702
Model 6-1/1, 15 plates	No.	60.61.701
Model 10-1/1, 32 plates	No.	60.11.581
Model 10-1/1, 26 plates	No.	60.11.602
Model 6-2/1, 34 plates	No.	60.62.017
Model 10-2/1, 52 plates	No.	60.12.022
Model 10-2/1, 42 plates	No.	60.12.062
Model 20-1/1, 60 plates	No.	60.21.293
Model 20-1/1, 50 plates	No.	60.21.294
Model 20-2/1, 120 plates	No.	60.22.400
Model 20-2/1, 100 plates	No.	60.22.399
Model 20-2/1, 84 plates	No.	60.22.398

Combi-Duo run-in rail for mobile oven rack

Model Combi-Duo 6-1/1 and 10-1/1	No.	60.75.761
Model Combi-Duo 6-2/1 and 10-2/1	No.	60.75.760

Run-in rail for mobile oven rack

Standard Model 6-1/1, 10-1/1	No.	60.75.115
Standard Model 6-2/1, 10-2/1	No.	60.74.650

Transport trolley Combi-Duo for mobile oven rack

For Combi-Duo 6-1/1 and 10-1/1, Dimensions W 561 D 842 H 1052 – 1478 mm	No.	60.75.388
For Combi-Duo 6-2/1 and 10-2/1, Dimensions W 773 D 961 H 1052 – 1478 mm	No.	60.75.387

Transport trolley Standard for mobile oven rack

Standard – 6-1/1, 10-1/1, dimensions W 525 D 911 H 990 mm	No.	60.74.000
Height-adjustable – 6-1/1, 10-1/1, dimensions W 525 D 911 H 800 – 1330 mm	No.	60.75.606
Standard – 6-2/1, 10-2/1, dimensions W 735 D 996 H 990 mm	No.	60.73.999
Height-adjustable – 6-2/1, 10-2/1, dimensions W 735 D 990 H 800 – 1330 mm	No.	60.75.605

Transport trolley for containers

Transport trolley for integrated fat drain system (Combi-Duo and floor units)	No.	60.73.309
---	-----	-----------

Sample calculation with Finishing.

Capacity Mobile plate rack	Size of event (number of persons)	Mobile plate racks, Thermocovers	Run-in rail	Transport trolley	Max. Plate height in mm	Max. Food height in mm
15/20 plates* with iCombi Pro 6-1/1	15/20	1	1	1	32/25	70/53
	30/40	2	1	2	32/25	70/53
	45/60	3	1	3	32/25	70/53
26/32 plates* with iCombi Pro 10-1/1	52/64	2	1	2	32/25	70/53
	78/96	3	1	3	32/25	70/53
	104/128	4	1	4	32/25	70/53
34 plates* with iCombi Pro 6-2/1	34	1	1	1	32	61
	68	2	1	2	32	61
	102	3	1	3	32	61
42/52 plates* with iCombi Pro 10-2/1	84/104	2	1	2	40/32	82/63
	126/156	3	1	3	40/32	82/63
	168/208	4	1	4	40/32	82/63
50/60 plates* with iCombi Pro 20-1/1	100/120	2	–	–	32/25	67/52
	150/180	3	–	–	32/25	67/52
	200/240	4	–	–	32/25	67/52
84/100/120 plates* with iCombi Pro 20-2/1	168/200/240	2	–	–	40/32/25	79/65/52
	252/300/360	3	–	–	40/32/25	79/65/52
	336/400/480	4	–	–	40/32/25	79/65/52

*Plate size up to 31 cm diameter

Mobile oven racks and hinging racks.



Mobile oven rack Model 6-1/1

Standard, 6 racks (rail distance 64 mm)	No.	60.61.420
Bakery standard (400 × 600 mm), 5 racks (rail distance 77 mm)*	No.	60.61.690

Mobile oven rack Model 10-1/1

Standard, 10 racks (rail distance 64 mm)	No.	60.11.600
8 racks (rail distance 80 mm)	No.	60.11.601
Bakery standard (400 × 600 mm), 8 racks (rail distance 81 mm)*	No.	60.11.599

Mobile oven rack Model 6-2/1

Standard, 6 racks (rail distance 64 mm)	No.	60.62.150
---	-----	-----------

Mobile oven rack Model 10-2/1

Standard, 10 racks (rail distance 63 mm)	No.	60.12.150
--	-----	-----------

Mobile oven rack Model 20-1/1

Standard, 20 racks (rail distance 65 mm)	No.	60.21.331
15 racks (rail distance 84 mm)	No.	60.21.287
16 racks (rail distance 80 mm)	No.	60.21.288
17 racks (rail distance 74 mm)	No.	60.21.289
Bakery standard (400 × 600 mm), 16 racks (rail distance 81 mm)*	No.	60.21.292
20 racks, max. rack height 1.60 m (rail distance 62 mm)	No.	60.21.245

Mobile oven rack Model 20-2/1

Standard, 20 racks (rail distance 65 mm)	No.	60.22.490
15 racks (rail distance 84 mm)	No.	60.22.394
16 racks (rail distance 80 mm)	No.	60.22.395
17 racks (rail distance 74 mm)	No.	60.22.396
20 racks, max. rack height 1.60 m (rail distance 62 mm)	No.	60.22.368

Hinging rack Model XS 6-2/3

Standard	No.	60.73.724
----------	-----	-----------

Hinging rack Model 6-1/1

Standard, 6 racks (rail distance 68 mm)	No.	60.61.373
5 racks (rail distance 85 mm)	No.	60.61.615
Chicken grill, 2 racks	No.	60.61.645
Meat trays, 6 racks (rail distance 72 mm)	No.	60.61.649
Bakery standard (400 × 600 mm), 5 racks (rail distance 86 mm)*	No.	60.61.576
Combi rack, bakery standard combined with 1/1 GN, 4 racks (rail distance 95 mm)*	No.	60.61.642

Hinging rack Model 10-1/1

Standard, 10 racks (rail distance 68 mm)	No.	60.11.447
8 racks (rail distance 85 mm)	No.	60.11.547
Chicken grill, 3 racks	No.	60.11.566
Meat trays, 10 racks (rail distance 72 mm)	No.	60.11.570
Bakery standard (400 × 600 mm), 8 racks (rail distance 90 mm)*	No.	60.11.541
Combi rack, bakery standard combined with 1/1 GN, 7 racks (rail distance 95 mm)*	No.	60.11.563

Hinging rack Model 6-2/1

Standard, 6 racks (rail distance 68 mm)	No.	60.62.123
5 racks (rail distance 85 mm)	No.	60.62.171
7 racks without L rails (rail distance 65 mm)	No.	60.62.168

Hinging rack Model 10-2/1

Standard, 10 racks (rail distance 68 mm)	No.	60.12.133
--	-----	-----------

GN accessories.

Rust-free stainless steel perforated container

1/1 GN (325 × 530 mm) 55 mm deep	No.	6015.1165
----------------------------------	-----	-----------

Rust-free stainless steel container

2/3 GN (325 × 354 mm) 20 mm deep	No.	6013.2302
2/3 GN (325 × 354 mm) 65 mm deep	No.	6013.2306
1/1 GN (325 × 530 mm) 20 mm deep	No.	6013.1102
1/1 GN (325 × 530 mm) 40 mm deep	No.	6013.1104
1/1 GN (325 × 530 mm) 65 mm deep	No.	6013.1106

Stainless steel grid

2/3 GN (325 × 354 mm)	No.	6010.2301
1/1 GN (325 × 530 mm)	No.	6010.1101
2/1 GN (650 × 530 mm)	No.	6010.2101
Bakery standard (400 × 600 mm)	No.	6010.0103

Dripping tray with drain lock

1/1 GN (325 × 530 mm)	No.	8710.1135
2/1 GN (650 × 530 mm)	No.	60.70.776

Special applications.



Chicken and duck superspike

Capacity 4 pcs, max. weight 1,300 g, 1/2 GN (325 × 265 mm)	No.	6035.1015
Capacity 6 pcs, max. weight 1,800 g, 1/1 GN (325 × 530 mm)	No.	6035.1016
Capacity 8 pcs, max. weight 1,300 g, 1/1 GN (325 × 530 mm)	No.	6035.1006
Capacity 10 pcs, max. weight 950 g, 1/1 GN (325 × 530 mm)	No.	6035.1010
Capacity: 8 pcs, max. weight 2,200 g, 1/1 GN (325 × 530 mm)	No.	6035.1009

CombiFry

1/2 GN (325 × 265 mm)	No.	6019.1250
2/3 GN (325 × 354 mm)	No.	60.73.619
1/1 GN (325 × 530 mm)	No.	6019.1150

Rib rack

1/1 GN (325 × 530 mm)	No.	6035.1018
-----------------------	-----	-----------

Grill and tandoori skewer

Grill and tandoori skewer frame 2/3 GN	No.	60.74.963
Grill and tandoori skewer frame 1/1 GN	No.	60.72.224
Set 2/3 GN (1 × skewer frame and five different skewers)	No.	60.75.782
Set 1/1 GN (1 × skewer frame and five different skewers)	No.	60.72.414
5 × skewers O 5 mm, 265 mm long for 2/3 GN	No.	60.75.783
5 × skewers □ 5 mm, 265 mm long for 2/3 GN	No.	60.75.784
5 × fish skewers 4 × 10 mm, 265 mm long for 2/3 GN	No.	60.75.785
3 × skewers O 5 mm, 530 mm long for 1/1 GN	No.	60.72.416
3 × skewers O 8 mm, 530 mm long for 1/1 GN	No.	60.72.417
3 × skewers □ 5 mm, 530 mm long for 1/1 GN	No.	60.72.418
3 × skewers □ 8 mm, 530 mm long for 1/1 GN	No.	60.72.419
3 × fish skewers 4 × 10 mm, 530 mm long for 1/1 GN	No.	60.72.420

Potato baker

1/1 GN (325 × 530 mm)	No.	6035.1019
-----------------------	-----	-----------

Lamb and suckling pig spit (1 lamb or 1 suckling pig)

Model 10-1/1, 10-2/1, 20-1/1, 20-2/1 to 12 kg (1/1 GN)	No.	60.70.819
Model 20-1/1 to 30 kg (1 skewer with carrier)	No.	6035.1003
Model 20-2/1 to 30 kg (1 skewer with carrier, second skewer for lamb or suckling pig optional)	No.	6035.1002
Optional skewer	No.	8710.1065

Pizza pan

Pizza up to Ø 280 mm	No.	60.71.158
----------------------	-----	-----------

* Please note that different air baffles are used in the cooking cabinet with GN versions and 400 × 600 mm bakery standard versions. The air baffle can be obtained from your Service Partner as a spare part, if it is not ordered as an option when the unit is purchased.

Combi-Duo.



Combi-Duo kit for iCombi Pro XS 6-2/3 and CombiMaster Plus XS 6-2/3

Model XS 6-2/3 on Model XS 6-2/3 right-sided hinge	No.	60.73.768
Model XS 6-2/3 on Model XS 6-2/3 left-sided hinge	No.	60.74.276

Combi-Duo kit for iCombi Pro 6-1/1 and 10-1/1

Model 6-1/1 E/G on Model 6-1/1 E Model 6-1/1 E/G on Model 10-1/1 E	No.	60.73.991
Unit size 6-1/1 E/G on unit size 6-1/1 G Unit size XS 6-2/3 on unit size 6-1/1 G	No.	60.75.751
Unit size XS 6-2/3 on unit size 6-1/1 E Unit size XS 6-2/3 on unit size 10-1/1 E	No.	60.75.755

Combi-Duo kit for 6-2/1 and 10-2/1

Model 6-2/1 E/G on Model 6-2/1 E Model 6-2/1 E/G on Model 10-2/1 E	No.	60.74.725
Unit size 6-2/1 E/G on unit size 6-2/1 G Unit size 6-1/1 E/G on unit size 6-2/1 G Unit size XS 6-2/3 on 6-2/1 G	No.	60.75.752
Unit size 6-1/1 E/G on unit size 6-2/1 E Unit size XS 6-2/3 on unit size 6-2/1 E Unit size XS 6-2/3 on unit size 10-2/1 E	No.	60.75.756

Setup variations for Combi-Duo

Levelling kit Model 6-1/1, 10-1/1, dimensions W 850 D 614 H 34 mm	No.	60.74.795
Levelling kit Model 6-2/1, 10-2/1, Dimensions W 1072 D 814 H 34 mm	No.	60.74.597
Kit with castors, unit sizes 6-1/1, 10-1/1, dimensions W 884 D 656 H 85 mm	No.	60.31.622
Kit with castors, unit sizes 6-2/1, 10-2/1, dimensions W 1106 D 856 H 85 mm	No.	60.31.635
Substructure with feet, unit sizes 6-1/1, 10-1/1, dimensions W 870 D 635 H 152 mm	No.	60.31.668
Substructure with feet, unit sizes 6-2/1, 10-2/1, dimensions W 1092 D 835 H 152 mm	No.	60.31.671
Stand I for Combi-Duo XS 6-2/3, standard, dimensions W 634 D 558 H 555 mm	No.	60.31.020
Stand II for Combi-Duo XS 6-2/3, standard, dimensions W 639 D 563 H 556 mm	No.	60.31.046
Stand I for Combi-Duo 6-1/1 on 6-1/1 and on 10-1/1 E, standard, dimensions W 860 D 685 H 200 mm	No.	60.31.200
Stand I for Combi-Duo 6-2/1 on 6-2/1 and on 10-2/1 E, standard, dimensions W 1082 D 885 H 200 mm	No.	60.31.203
Stand I for Combi-Duo XS 6-2/3, with castors, dimensions W 683 D 656 H 567 mm	No.	60.31.170
Stand I for Combi-Duo 6-1/1 on 6-1/1 and on 10-1/1 E, with castors, dimensions W 884 D 763 H 200 mm	No.	60.31.201
Stand I for Combi-Duo 6-2/1 on 6-2/1 and on 10-2/1 E, with castors, dimensions W 1106 D 963 H 200 mm	No.	60.31.204

Combi-Duo.

Hinging rack Combi-Duo Model 6-1/1

Combi-Duo version, 5+1 racks (top rack is removable for a max. rack height of 1.60 m, with floor setup 6-1/1 E on 10-1/1 E)	No.	60.61.678
---	-----	-----------

Hinging rack Combi-Duo Model 6-2/1

Combi-Duo version, 5+1 racks (top rack is removable for a max. rack height of 1.60 m, with floor setup 6-2/1 E on 10-2/1 E)	No.	60.62.188
---	-----	-----------

Integrated fat drain kit for Combi-Duo

to be set up on the levelling kit Combi-Duo 6-1/1 and 10-1/1	No.	60.75.873
to be set up on Stand I Combi-Duo 6-1/1 and 10-1/1	No.	60.75.406
to be set up on the levelling kit Combi-Duo 6-2/1 and 10-2/1	No.	60.75.876
to be set up on Stand I Combi-Duo 6-2/1 and 10-2/1	No.	60.75.411

Extras.

VarioSmoker

VarioSmoker Model G	No.	60.75.373
VarioSmoker Model E/F	No.	60.75.371

USB core probe

Sous-vide core probe for tabletop and floor units	No.	60.76.316
1 external core probe for tabletop units	No.	60.76.317
1 external core probe for floor units	No.	60.76.318
Extension set for USB core probes	No.	60.76.876

Positioning aid for core probe

Model 6-1/1, 10-1/1, 6-2/1, 10-2/1, 20-1/1 and 20-2/1	No.	60.71.022
---	-----	-----------

Pull-out rails for hinging racks with 68 mm rail spacing

For iCombi Pro and iCombi Classic, Model 6-1/1, 10-1/1	N°:	60.76.894
For SelfCookingCenter and CombiMaster Plus (from 09/2011), Model 61, 101	N°:	60.76.897

Setup variations.



Installation kit

UltraVent XS including installation kit	No.	60.74.063
UltraVent Plus XS including installation kit	No.	60.74.405

MobilityLine floor unit

Mobile base frame 20-1/1	No.	60.21.334
Mobile base frame 20-2/1	No.	60.22.496

Exhaust air technology.

Extraction hood, UltraVent and UltraVent Plus

UltraVent XS Combi-Duo	No.	60.73.943
UltraVent Plus XS Combi-Duo	No.	60.74.404
UltraVent Combi-Duo Model 6-1/1, 10-1/1	No.	60.76.169
UltraVent Plus Combi-Duo Model 6-1/1, 10-1/1	No.	60.76.173
Extraction hood Combi-Duo Model 6-1/1, 10-1/1	No.	60.76.221
UltraVent Combi-Duo Model 6-2/1, 10-2/1	No.	60.76.170
UltraVent Plus Combi-Duo Model 6-2/1, 10-2/1	No.	60.76.174
Extraction hood Combi-Duo Model 6-2/1, 10-2/1	No.	60.76.222
UltraVent, Model XS 6-2/3	No.	60.73.865
UltraVent Plus, Model XS 6-2/3	No.	60.74.394
UltraVent, Model 6-1/1, 10-1/1	No.	60.75.134
UltraVent Plus, Model 6-1/1, 10-1/1	No.	60.75.142
Extraction hood, Model 6-1/1, 10-1/1	No.	60.76.217
UltraVent, Model 6-2/1, 10-2/1	No.	60.75.135
UltraVent Plus, Model 6-2/1, 10-2/1	No.	60.75.143
Extraction hood, Model 6-2/1, 10-2/1	No.	60.76.218
UltraVent, Model 20-1/1	No.	60.75.136
UltraVent, Model 20-2/1	No.	60.75.137
Extraction hood, Model 20-1/1	No.	60.76.219

Stands.



Stand Model XS 6-2/3

Stand XS, standard, W 629 D 438 H 148 mm	No.	60.31.029
Stand I, standard, dimensions W 634 D 558 H 931 mm	No.	60.31.018
Stand I, with castors, dimensions W 683 D 656 H 943 mm	No.	60.31.169
Stand II, standard, dimensions W 639 D 563 H 932 mm	No.	60.31.044

Levelling kit and stands Model 6-1/1 and 10-1/1

Levelling kit, unit sizes 6-1/1, 10-1/1, dimensions W 850 D 614 H 34 mm	No.	60.74.795
Kit with castors, unit sizes 6-1/1, 10-1/1, dimensions W 884 D 656 H 85 mm	No.	60.31.622
Substructure with feet, unit sizes 6-1/1, 10-1/1, dimensions W 870 D 635 H 152 mm	No.	60.31.668
Stand I, standard, Dimensions W 860 D 685 H 699 mm	No.	60.31.089
Stand I, with castors, Dimensions W 884 D 763 H 699 mm	No.	60.31.095
Stand II, standard, Dimensions W 860 D 703 H 699 mm	No.	60.31.086
Stand II, with castors, Dimensions W 884 D 769 H 699 mm	No.	60.31.103
Stand II, bakery standard, standard, dimensions W 860 D 703 H 699 mm	No.	60.31.209
Stand II, bakery standard, with castors, dimensions W 884 D 769 H 699 mm	No.	60.31.210
Stand II, bakery standard, UltraVent version, standard, dimensions W 860 D 703 H 945 mm	No.	60.31.212
Stand II, bakery standard, UltraVent version, with castors, dimensions W 884 D 769 H 945 mm	No.	60.31.213
Stand II, MobilityLine, dimensions W 1199 D 894 H 792 mm	No.	60.31.164
Stand III, standard, dimensions W 860 D 703 H 699 mm	No.	60.31.091
Stand III, with castors, dimensions W 883 D 769 H 699 mm	No.	60.31.105
Stand III, UltraVent version, standard, dimensions W 860 D 703 H 945 mm	No.	60.31.214

Levelling kit and stand Model 6-1/1 and 10-1/1

Stand III, UltraVent version, with castors, dimensions W 884 D 769 H 945 mm	No.	60.31.215
Stand IV, standard, dimensions W 860 D 703 H 699 mm	No.	60.31.093
Stand IV, with castors, dimensions W 884 D 769 H 699 mm	No.	60.31.107

Levelling kit and stand Model 6-2/1 and 10-2/1

Levelling kit, unit sizes 6-2/1, 10-2/1, dimensions W 1072 D 814 H 34 mm	No.	60.74.597
Kit with castors, unit sizes 6-2/1, 10-2/1, dimensions W 1106 D 856 H 85 mm	No.	60.31.635
Substructure with feet, unit sizes 6-2/1, 10-2/1, dimensions W 1092 D 835 H 152 mm	No.	60.31.671
Stand I, standard, dimensions W 1082 D 885 H 699 mm	No.	60.31.090
Stand I, with castors, Dimensions W 1106 D 963 H 699 mm	No.	60.31.102
Stand II, standard, Dimensions W 1082 D 903 H 699 mm	No.	60.31.087
Stand II, with castors, Dimensions W 1106 D 969 H 699 mm	No.	60.31.104
Stand II, MobilityLine, dimensions W 1421 D 1084 H 792 mm	No.	60.31.165
Stand III, standard, dimensions W 1082 D 903 H 699 mm	No.	60.31.092
Stand III, with castors, dimensions W 1105 D 969 H 699 mm	No.	60.31.106
Stand III, UltraVent version, standard, dimensions W 1082 D 903 H 945 mm	No.	60.31.216
Stand III, UltraVent version, with castors, dimensions W 1106 D 969 H 945 mm	No.	60.31.217
Stand IV, standard, dimensions W 1082 D 903 H 699 mm	No.	60.31.094
Stand IV, with castors, Dimensions W 1106 D 969 H 699 mm	No.	60.31.108

Installation accessories.



Trolley levelling device for mobile oven rack

Model 20-1/1	No.	60.21.262
Model 20-2/1	No.	60.22.380

Unit raiser

Model 20-1/1, 20-2/1	No.	60.70.407
----------------------	-----	-----------

Raiser for mobile oven rack

Model 20-1/1	No.	60.21.297
Model 20-2/1	No.	60.22.386

Heat shield for side panel

Left heat shield, Model XS 6-2/3	No.	60.74.182
Left heat shield, Model 6-1/1	No.	60.75.110
Right heat shield, Model 6-1/1	No.	60.75.113
Left heat shield, Model 10-1/1	No.	60.75.773
Right heat shield, Model 10-1/1	No.	60.75.771
Left heat shield, Model 6-2/1	No.	60.75.769
Right heat shield, Model 6-2/1	No.	60.75.768
Left heat shield, Model 10-2/1	No.	60.75.776
Right heat shield, Model 10-2/1	No.	60.75.774
Left heat shield, Model 20-1/1	No.	60.75.829
Left heat shield, Model 20-2/1	No.	60.75.826

Flow guard for gas units

Model 6-1/1	No.	70.01.339
Model 10-1/1	No.	70.01.340
Model 6-2/1	No.	70.01.431
Model 10-2/1	No.	70.01.582
Model 20-1/1	No.	70.01.583
Model 20-2/1	No.	70.01.492

Flue gas collector for gas units

Model 6-1/1	No.	70.01.360
Model 10-1/1	No.	70.01.376
Model 6-2/1	No.	70.01.432
Model 10-2/1	No.	70.01.586
Model 20-1/1	No.	70.01.587
Model 20-2/1	No.	70.01.493

Handle holder for mobile oven rack

Model 20-1/1, 20-2/1	No.	60.75.895
----------------------	-----	-----------

Unit connection kit

Model XS 6-2/3, 6-1/1, 10-1/1, 6-2/1, 10-2/1, 20-1/1, 20-2/1	No.	60.70.464
--	-----	-----------

Condensation breaker

Model XS 6-2/3 (H 438 mm)	No.	60.74.037
Model 6-1/1, 10-1/1, 6-2/1 and 10-2/1 (H 458 mm)	No.	60.72.592
Model 20-1/1 and 20-2/1 (H 480 mm)	No.	60.75.326

Wall mounting

Model XS 6-2/3	No.	60.30.968
Model 6-1/1	No.	60.31.168

Table extension

Model 6-1/1 and 10-1/1	No.	60.11.655
------------------------	-----	-----------

Care products.

Active Green cleaner tab (for iCombi Pro and iCombi Classic)

Active Green cleaner tabs, 150 pcs	No.	56.01.535
Active Green cleaner tabs, NaOH free, 150 pcs (for Singapore only)	No.	56.01.537

Cleaner tab (for all SelfCookingCenter and CombiMaster Plus)

Cleaner tabs, 100 pcs	No.	56.00.210
Cleaner tabs, NaOH free, 130 pcs (for Singapore only)	No.	56.00.218

Care tab (for iCombi Pro, iCombi Classic and SelfCookingCenter with Efficient CareControl)

Care tabs, 150 pcs	No.	56.00.562
--------------------	-----	-----------

Rinse aid tab (for SelfCookingCenter units without Efficient CareControl and CombiMaster Plus)

Rinse aid tabs, 50 pcs	No.	56.00.211
------------------------	-----	-----------

Liquid cleaner (for all CombiMaster and ClimaPlus Combi units)

Grill cleaner (for all CombiMaster and ClimaPlus Combi units)	No.	9006.0153
Liquid rinsing chemical (for ClimaPlus Combi with CleanJet)	No.	9006.0137

Descaler (for SelfCookingCenter without CareControl, CombiMaster, ClimaPlus Combi)

Descaler, 10 litres	No.	6006.0110
Foot pump for descaling the steam generator	No.	6004.0203

Handheld pressure sprayer

Handheld pressure sprayer for manual cleaning	No.	6004.0100
---	-----	-----------

➔ **More information on original RATIONAL accessories at:**
rational-online.com/sg/accessories



RATIONAL Cooking Systems Pte Ltd
(a subsidiary of RATIONAL International AG)
25 International Business Park
#02-15/17 German Centre
Singapore, 609916

Tel +65 68095850
Fax +65 68095899

info@rational-online.sg
rational-online.com

